

Mobile Hydraulic Crane Operator Standards 20 Tonnes (22.05 US Tons) and Under

July 2022

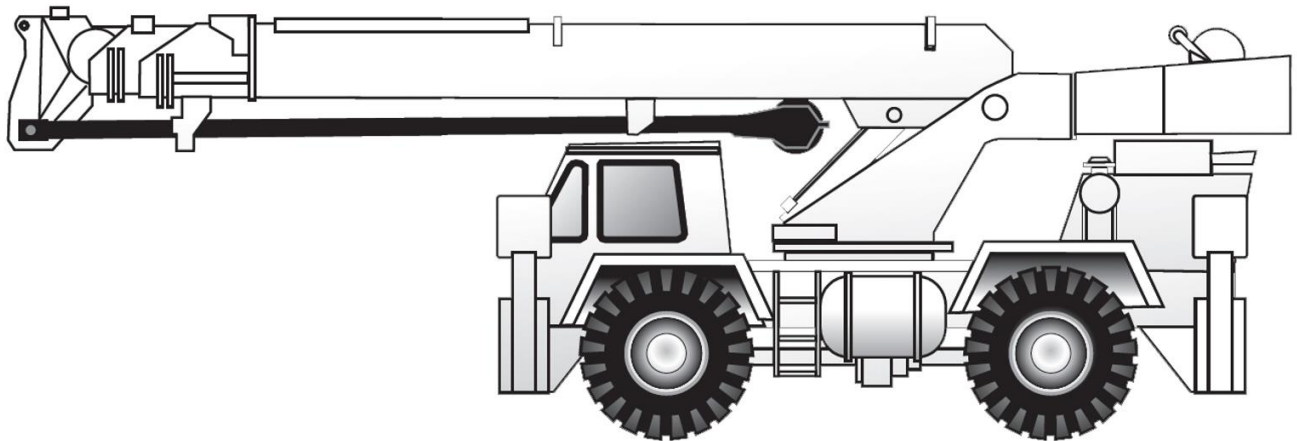

Copyright © 2011 BC Crane Safety
www.bccranesafety.ca

This publication may not be reproduced in any form without permission by
BC Crane Safety

TABLE OF CONTENTS

<u>FOREWORD</u>	5
<u>ACKNOWLEDGEMENTS</u>	6
<u>OCCUPATION ANALYSIS CHART</u>	8
<u>SUGGESTED INSTRUCTIONAL TIME ALLOTMENTS</u>	11
<u>A. SAFETY</u>	15
Unit Standard A1u K	15
Unit Standard A2u K	19
Unit Standard A3u W	20
<u>B. COMMUNICATIONS</u>	22
Unit Standard B1u K	22
Unit Standard B2u K	23
Unit Standard B3u W	24
Unit Standard B4u W	25
<u>C. CRANES</u>	27
Unit Standard C3u K	27
Unit Standard C6u K	30
Unit Standard C7u K	35
Unit Standard C10u K	36
Unit Standard C13u K	40
Unit Standard C14u K	43
Unit Standard C17u K	46
Unit Standard C20u W	48
Unit Standard C23u W	52
Unit Standard C26u W	55
Unit Standard C29u W	58
<u>D. RIGGING AND LIFTING THEORY</u>	61
Unit Standard D1u K	61
Unit Standard D2u K	62
Unit Standard D3u K	65
Unit Standard D4u W	68
<u>E. HOISTING FUNDAMENTALS</u>	70
Unit Standard E1u K	70
Unit Standard E4u K	72
Unit Standard E7u W	73
<u>F. TRANSPORTATION AND/OR TRAVEL</u>	75
Unit Standard F1u K	75
Unit Standard F4u K	76
Unit Standard F5u W	78
<u>G. SITE PLANNING AND CRANE POSITIONING</u>	80
Unit Standard G1u K	80
Unit Standard G2u K	81
Unit Standard G3u W	83
<u>I. MAINTENANCE AND SERVICE</u>	85
Unit Standard I3u K	85
Unit Standard I6u K	87
Unit Standard I9u W	90

<u>Unit Standard I10u W</u>	93
<u>Unit Standard I11u W</u>	95
<u>TRAINING PROVIDER STANDARDS</u>	97
<u>RECOMMENDED REFERENCE MATERIALS</u>	98

FOREWORD

This document specifies the standards that must be met by an operator to be certified for operation of a Mobile Hydraulic Crane with a lifting capacity of Under 20 Tonnes (22.05 US Tons).

These are competency based operator standards, separated into theoretical and practical components. Industry believes a crane operator becomes competent through building on theoretical knowledge with real world experience.

The theoretical component is made up of the Knowledge Unit Standards, which:

- can be learned in a classroom setting with a qualified instructor, or
- learned through self-study, either on-line or through printed materials, and
- are assessed by means of a formal independent third party examination.

The practical component is made up of the Workplace Unit Standards, which:

- may be first learned in a simulated setting such as a training yard, and
- are fully developed through hands-on work experience, and
- are assessed on the job by an independent third party Registered Workplace Assessor.

Safe working practices, though not always specified, are a part of the safe working and learning conditions underlying all these standards and will be required in the presentation of evidence to meet these standards.

This document will be useful in guiding competency-based training of crane operators who operate Mobile Cranes 20 Tonnes (22.05 US Tons) and Under. The competency standards provide a structure for on the job training and industry wishes to see trainers take full advantage of opportunities for on the job training.

This document also includes a list of recommended reference textbooks that are available to support achievement of the Knowledge Units.

ACKNOWLEDGEMENTS

The BC Association for Crane Safety (BC Crane Safety) is a non-profit society which was formed in 2005 to lead and coordinate activities and initiatives which promote safer crane operation in BC. BC Crane Safety was started and is governed by BC's crane industry through a volunteer board of industry stakeholders. A main area of concern for the organization is the development of standards for competent crane operation in BC and the promotion of industry standards to drive excellence in crane operation and operator training.

In 2005 a representative group of crane owners from the Mobile Crane, Boom Truck and Tower Crane industries in BC began work to identify standards required for all crane operators in BC. By mid-2006 the industry had endorsed a set of competency standards across all crane types, including core competencies which are common to all crane types. These standards were approved by WorkSafeBC.

The crane operator standards have been developed through extensive consultation with a broad cross section of stakeholders from BC's crane industry – crane owners, operators and other occupations which make occasional yet regular use of cranes.

This work would not have been possible without the contribution of thousands of hours of industry stakeholder time through the BC Crane Safety task groups. BC Crane Safety wishes to thank those Subject Matter Experts (SMEs) who contributed to this development effort.

BC Crane Safety also wishes to acknowledge the funding support for this work it has received from WorkSafeBC.

SAFETY ADVISORY

Be advised that references to the parts of the WorkSafeBC regulation contained within these materials do not/may not reflect the most recent Occupational Health and Safety Regulation (the current Standards and Regulation in BC can be obtained on the following website: <http://www.worksafebc.com>). Please note that it is always the responsibility of any person using these materials to inform him/herself about the Occupational Health and Safety Regulation pertaining to his/her work.

OCCUPATION ANALYSIS CHART

Mobile Hydraulic Crane 20 Tonnes (22.05 US Tons) and Under Standards Profile Chart						
A. Safety	A1u K Demonstrate knowledge of safe working practices for crane operators	A2u K Demonstrate knowledge of power line hazards and high voltage <u>equipment</u>	A3u W Comply with WorkSafeBC Occupational Health and Safety Regulation (OHSR)			
B. Communications	B1u K Demonstrate knowledge of hand signals	B2u K Demonstrate knowledge of radio communications	B3u W Use hand signals in the workplace	B4u W Use radio communications in the <u>workplace</u>		
C. Cranes	C3u K Demonstrate knowledge of terminology related to craning and hoisting functions and systems for mobile hydraulic cranes 20 tonnes (22.05 US tons) and under	C6u K Demonstrate knowledge of crane operations for mobile hydraulic cranes 20 tonnes (22.05 US tons) and under	C7u K Demonstrate knowledge of regulatory requirements pertaining to cranes	C10u K Demonstrate knowledge of crane components and attachments for mobile hydraulic cranes 20 tonnes (22.05 US tons) and under	C13u K Demonstrate knowledge of pre-operational requirements in mobile hydraulic crane 20 tonnes (22.05 US tons) and under operations	C14u K Demonstrate knowledge of power transfer for mobile cranes
	C17u K Demonstrate knowledge to leave a mobile hydraulic crane 20 tonnes (22.05 US tons) and under unattended	C20u W Demonstrate the use of crane components and attachments for mobile hydraulic cranes 20 tonnes (22.05 US tons) and under in the workplace	C23u W Conduct pre-operational inspections of mobile hydraulic cranes 20 tonnes (22.05 US tons) and under in the <u>workplace</u>	C26u W Operate a mobile hydraulic crane 20 tonnes (22.05 US tons) and under safely	C29u W Leave a mobile hydraulic crane 20 tonnes (22.05 US tons) and under unattended	
D. Rigging and Lifting Theory	D1u K Demonstrate knowledge of lifting theory and <u>forces</u>	D2u K Demonstrate knowledge of slings (all types), rigging hardware, materials, inspection and capacity cards	D3u K Demonstrate knowledge of wire rope hoist line construction and inspection	D4u W Use slings (all types) rigging hardware, materials and capacity cards in the workplace		
E. Hoisting Fundamentals	E1u K Demonstrate knowledge of determining load weights using fundamental math functions and calculations	E4u K Demonstrate knowledge of load charts and load calculations for mobile hydraulic cranes 20 tonnes (22.05 US tons) and under	E7u W Interpret load charts and load study drawings to configure a mobile hydraulic crane 20 tonnes (22.05 US tons) and under for workplace operation			

Mobile Hydraulic Crane Operator Standards 20 Tonnes (22.05 US Tons) and Under

<p>F. Transportation and/or Travel</p>	<p>F1u K Demonstrate knowledge of BC Ministry of Transportation – Commercial Transport rules and regulations</p>	<p>F4u K Demonstrate knowledge to prepare a mobile hydraulic crane 20 tonnes (22.05 US tons) and under for transport and/or travel</p>	<p>F5u W Prepare a mobile crane for transport and/or travel to a worksite following all highway and traffic rules and <u>regulations</u></p>		
<p>G. Site Planning and Crane Positioning</p>	<p>G1u K Demonstrate knowledge of site assessment tools</p>	<p>G2u K Demonstrate knowledge of safely locating and positioning a crane</p>	<p>G3u W Conduct an accurate site assessment and safely position a crane in the workplace</p>		
<p>I. Maintenance and Service</p>	<p>I3u K Demonstrate knowledge of inspecting engines, monitoring devices and hydraulic systems on mobile hydraulic cranes 20 tonnes (22.05 US tons) and under</p>	<p>I6u K Demonstrate knowledge of servicing and maintenance procedures for mobile hydraulic cranes 20 tonnes (22.05 US tons) and under</p>	<p>I9u W Complete mobile hydraulic crane 20 tonnes (22.05 US tons) and under maintenance checklists (engine on/engine off) and maintain engines to manufacturer's specifications</p>	<p>I10u W Perform routine inspections and maintenance of hydraulic systems on mobile cranes</p>	<p>I11u W Maintain an equipment logbook to retain a permanent written record of maintenance and <u>repairs</u></p>

MOBILE HYDRAULIC CRANE OPERATOR 20 TONNES (22.05 US TONS) AND UNDER OPERATOR STANDARDS

SUGGESTED INSTRUCTIONAL TIME ALLOTMENTS

Unit	Section A – Safety – Knowledge	15% of Time
-------------	---------------------------------------	--------------------

- | | | |
|-------|--|--|
| A1u K | Demonstrate knowledge of safe working practices for crane operators | |
| A2u K | Demonstrate knowledge of power line hazards and high voltage equipment | |

Unit	Section A – Safety – Practical	
-------------	---------------------------------------	--

- | | | |
|-------|---|--|
| A3u W | Comply with WorkSafeBC Occupational Health and Safety Regulation (OHSR) | |
|-------|---|--|

Unit	Section B - Communications – Knowledge	10% of Time
-------------	---	--------------------

- | | | |
|-------|---|--|
| B1u K | Demonstrate knowledge of hand signals | |
| B2u K | Demonstrate knowledge of radio communications | |

Unit	Section B - Communications – Practical	
-------------	---	--

- | | | |
|-------|---|--|
| B3u W | Use hand signals in the workplace | |
| B4u W | Use radio communications in the workplace | |

Unit	Section C – Cranes – Knowledge	20% of Time
-------------	---------------------------------------	--------------------

- | | | |
|--------|--|--|
| C3u K | Demonstrate knowledge of terminology related to craning and hoisting functions and systems for mobile hydraulic cranes 20 tonnes (22.05 US tons) and under | |
| C6u K | Demonstrate knowledge of crane operations for mobile hydraulic cranes 20 tonnes (22.05 US tons) and under | |
| C7u K | Demonstrate knowledge of regulatory requirements pertaining to cranes | |
| C10u K | Demonstrate knowledge of crane components and attachments for mobile hydraulic cranes 20 tonnes (22.05 US tons) and under | |
| C13u K | Demonstrate knowledge of pre-operational requirements in mobile hydraulic crane 20 tonnes (22.05 US tons) and under operations | |
| C14u K | Demonstrate knowledge of power transfer for mobile cranes | |
| C17u K | Demonstrate knowledge to leave a mobile hydraulic crane 20 tonnes (22.05 US tons) and under unattended | |

Unit	Section C - Cranes – Practical	
-------------	---------------------------------------	--

- | | | |
|--------|--|--|
| C20u W | Demonstrate the use of crane components and attachments for mobile hydraulic cranes 20 tonnes (22.05 US tons) and under in the workplace | |
| C23u W | Conduct pre-operational inspections of mobile hydraulic cranes 20 tonnes (22.05 US tons) and under in the workplace | |
| C26u W | Operate a mobile hydraulic crane 20 tonnes (22.05 US tons) and under safely | |
| C29u W | Leave a mobile hydraulic crane 20 tonnes (22.05 US tons) and under unattended | |

Unit Section D – Rigging and Lifting Theory – Knowledge 15% of Time

- D1u K Demonstrate knowledge of lifting theory and forces
- D2u K Demonstrate knowledge of slings (all types), rigging hardware, materials, inspection and capacity cards
- D3u K Demonstrate knowledge of wire rope hoist line construction and inspection

Unit Section D - Rigging and Lifting Theory – Practical

- D4u W Use slings (all types) rigging hardware, materials and capacity cards in the workplace

Unit Section E – Hoisting Fundamentals – Knowledge 20% of Time

- E1u K Demonstrate knowledge of determining load weights using fundamental math functions and calculations
- E4u K Demonstrate knowledge of load charts and load calculations for mobile hydraulic cranes 20 tonnes (22.05 US tons) and under

Unit Section E – Hoisting Fundamentals – Practical

- E7u W Interpret load charts and load study drawings to configure a mobile hydraulic crane 20 tonnes (22.05 US tons) and under for workplace operation

Unit Section F - Transportation and/or Travel – Knowledge 5% of Time

- F1u K Demonstrate knowledge of BC Ministry of Transportation – Commercial Transport rules and regulations
- F4u K Demonstrate knowledge to prepare a mobile hydraulic crane 20 tonnes (22.05 US tons) and under for transport and/or travel

Unit Section F - Transportation and/or Travel – Practical

- F5u W Prepare a mobile crane for transport and/or travel to a worksite following all highway and traffic rules and regulations

Unit Section G - Site Planning and Crane Positioning– Knowledge 8% of Time

- G1u K Demonstrate knowledge of site assessment tools
- G2u K Demonstrate knowledge of safely locating and positioning a crane

Unit Section G - Site Planning and Crane Positioning – Practical

- G3u W Conduct an accurate site assessment and safely position a crane in the workplace

Unit Section I - Maintenance and Service – Knowledge 7% of Time

- I3u K Demonstrate knowledge of inspecting engines, monitoring devices and hydraulic systems on mobile hydraulic cranes 20 tonnes (22.05 US tons) and under
- I6u K Demonstrate knowledge of servicing and maintenance procedures for mobile hydraulic cranes 20 tonnes (22.05 US tons) and under

Unit	Section I - Maintenance and Service – Practical
I9u W	Complete mobile hydraulic crane 20 tonnes (22.05 US tons) and under maintenance checklists (engine on/engine off) and maintain engines to manufacturer's specifications
I10u W	Perform routine inspections and maintenance of hydraulic systems on mobile cranes
I11u W	Maintain an equipment logbook to retain a permanent written record of maintenance and repairs

TOTAL ALL UNITS 100%

OPERATOR STANDARDS

SECTION A

SAFETY

A. Safety

Unit Standard A1u K

Demonstrate knowledge of safe working practices for crane operators

Purpose

This unit of competency covers knowledge of potential hazards in the workplace.

Task 1

Describe workplace hazards in terms of the WorkSafeBC Occupational Health and Safety Regulation (OHSR) and how to eliminate, isolate, or minimize hazards.

Performance standards

1.1 Identify and describe energy source hazards.

Must include

- hydraulic
- electrical
- pneumatic
- potential energy

1.2 Identify and describe overhead hazards.

Must include

- power lines
- cranes/other equipment
- obstructions

1.3 Identify and describe mobile machinery hazards.

Must include

- trucks
- cranes
- forklift trucks
- mobile equipment

1.4 Identify and describe rotating equipment hazards.

Must include

- belts
- pulleys
- sheaves
- sprockets
- chains
- couplings
- pinch points
- barriers

Task 2

Demonstrate knowledge of worksite hazard risk assessment and risk management procedures.

Performance standards

2.1 Describe risk assessment procedures and risk management procedures.

Must include

- responsibility to maintain a safe work environment
- changing weather
- frozen surfaces
- traffic
- location
- operating blind
- slips
- trips and falls
- injury to others
- injury from moving machinery

2.2 Explain methods of communicating risks and risk situations to others.

Must include

- signage
- tagging
- verbal communications
- written communications
- safe work cards
- risk hazard assessment procedures

2.3 Explain how to notify local utilities when operating near utility lines or potential hazards.

Must include

- assurance in writing
- safety watcher

Task 3

Demonstrate knowledge of accident and incident reporting procedures.

Performance standard

3.1 Identify and explain requirements for recording an accident and/or incident.

Must include

- report form completion
- report form processing

Task 4

Describe personal protection equipment.

Performance standards

4.1 Identify and describe breathing protection equipment.

Must include

- respirators and filters

4.2 Identify and describe personal protective equipment (PPE) and clothing.

Must include

- hard hat
- safety boots
- protective eyewear
- hearing protection
- high visibility apparel
- hand protection

Task 5

Demonstrate knowledge of response to fire emergencies.

Performance standards

5.1 Identify fire extinguisher types and describe their servicing and use.

Must include

- extinguisher types and capacities
- use of extinguishers

5.2 Explain procedures for fighting electrical fires.

Must include

- isolate power
- appropriate firefighting equipment

5.3 Explain fire emergency response and evacuation procedures in accordance with industry practice.

Task 6

Describe procedure for emergency rescue from a crane.

Performance standard

6.1 Describe emergency rescue procedures.

Must include

- crane fire
- crane tip-over (access to cab is blocked)
- submerged crane

Task 7

Describe the 3 point contact method when mounting and dismounting equipment.

Performance standard

7.1 Describe the 3 point contact method when mounting and dismounting equipment.

Must include

- cranes
- other heavy equipment
- manufacturer specific access systems
- handholds and step ladders

Task 8

Describe the requirements for leaving a crane unattended.

Performance standard

8.1 Describe requirements for leaving a crane unattended.

Must include

- knowledge of applicable WorkSafeBC regulations

A. Safety

Unit Standard A2u K

Demonstrate knowledge of power line hazards and high voltage equipment

Purpose

This unit standard covers knowledge about crane operation around high voltage equipment.

Task 1

Describe procedures for operating in proximity of overhead conductors.

Performance standards

1.1 Explain operating procedures in the vicinity of overhead conductors.

Must include

- interpret signage related to high voltage
- state safe limits of approach to overhead conductors
- assurance in writing from the local power authority
- critical lift procedure
- how to determine voltage
- risk factors when working near powerlines (wind, load size/profile)
- use of tag lines

1.2 Explain protocol if contact is made with high voltage equipment.

A. Safety

Unit Standard A3u W

Comply with WorkSafeBC Occupational Health and Safety Regulation (OHSR)

Purpose

Interpret and comply with WorkSafeBC Occupational Health and Safety Regulation (OHSR), standards and guidelines.

Task 1

Comply with WorkSafeBC Occupational Health and Safety Regulation (OHSR) and procedures applicable to workers in the workplace by demonstrating knowledge gained in training.

Performance standards

- 1.1 Complete reporting procedures accurately.
- 1.2 Perform thorough workplace inspections.
- 1.3 Comply with and adhere to WorkSafeBC Occupational Health and Safety Regulation (OHSR), standards and guidelines in the workplace.

For example

- safe operating practices
- load safely landed and supported
- remain at controls with suspended load

OPERATOR STANDARDS

SECTION B

COMMUNICATIONS

B. Communications

Unit Standard B1u K

Demonstrate knowledge of hand signals

Purpose

Demonstrate knowledge of hand signals used in crane operations.

Task 1

Describe the hand signals used during crane operations.

Performance standards

- 1.1 Describe hand signals accurately.
- 1.2 Identify and interpret hand signals accurately.
- 1.3 Explain requirements of the signal person.
- 1.4 Describe relaying signals for a blind lift

B. Communications

Unit Standard B2u K

Demonstrate knowledge of radio communications

Purpose

Demonstrate knowledge of the use of radio communications in the workplace.

Task 1

Describe the use of two-way electronic voice communication devices.

Performance standards

1.1 Describe the basic functions of the radio communication devices.

1.2 Explain language and terminology used during radio communication.

Must include

- short form words and phrases
- use of 12 o'clock (clock face positioning reference) to aid in direction giving and interpreting

1.3 Demonstrate and test two-way communication devices in a classroom environment.

Must include

- requirement to stop operation due to lost contact or interference

B. Communications

Unit Standard B3u W

Use hand signals in the workplace

Purpose

Demonstrate ability to use hand signals correctly in crane operations.

Task 1

Use hand signals and respond to hand signals during crane operations.

Performance standards

- 1.1 Use hand signals accurately.
- 1.2 Identify and interpret hand signals of others accurately.
- 1.3 Use hand signals to aid in the safe and correct completion of a crane operation.

B. Communications

Unit Standard B4u W

Use radio communications in the workplace

Purpose

Demonstrate ability to use radio communications in the workplace.

Task 1

Use a two-way electronic voice communication device in the workplace.

Performance standards

- 1.1 Use basic functions of the radio communication devices according to equipment instructions.
- 1.2 Use appropriate language and terminology during radio communication.
- 1.3 Use two-way communication devices to relay clear, concise, relevant information.

OPERATOR STANDARDS

SECTION C

CRANES

C. Cranes

Unit Standard C3u K

Demonstrate knowledge of terminology related to craning and hoisting functions and systems for mobile hydraulic cranes 20 tonnes (22.05 US tons) and under

Purpose

Demonstrate knowledge of terminology, functions and systems related to craning and craning concepts.

Task 1

Describe terms related to cranes commonly used in the work environment.

Performance standards

1.1 Explain terms related to crane operations:

Must include

- wire rope
- fittings
- drums
- hooks
- sheaves
- winch
- slew / swing
- hoist
- boom
- swing brake
- swing dog
- overload protection systems
- load monitoring and indicating systems
- anti-two block system
- outriggers/stabilizers
- counterweight
- jib
- load block / overhaul ball
- parts of line
- wedge socket assemblies
- crawler tracks (mini crawler cranes)
- boom hoist cylinders

Task 2

Demonstrate knowledge of travel braking systems in crane operations.

Performance standards

2.1 Identify components of the braking systems and describe their functions.

Must include

- air compressor
- brake chambers
- drums
- brake shoes and pads
- slack adjusters

2.2 Describe defects or malfunctions of braking systems.

Must include

- air compressors
- brake chambers
- drums
- brake shoes and pads
- slack adjusters

Task 3

Demonstrate knowledge of hoisting functions and systems for crane operation.

Performance standards

3.1 Identify components of hoisting systems and describe their functions.

Must include

- hydraulic boom (extension/retraction, boom hoist cylinders)
- drums
- hooks
- sheaves
- winch
- brakes
- load line

3.2 Describe defects or malfunctions of hoisting systems.

Must include

- hydraulic boom (wear pads, cylinders, chain extended booms)
- drums
- hooks
- sheaves
- winch
- brakes
- load line

C. Cranes

Unit Standard C6u K

Demonstrate knowledge of crane operations for mobile hydraulic cranes 20 tonnes (22.05 US tons) and under

Purpose

This unit provides the knowledge required to operate cranes to hoist and place loads in a safe and efficient manner.

Task 1

Demonstrate knowledge to correctly operate a crane with and without a load according to manufacturer's specifications.

Performance standards

1.1 Explain the safe and correct operation of a crane without a load.

Must include

- booming up and booming down
- telescoping in and out
- swinging/slewing clockwise and counter clockwise
- hoisting up and down
- travel on site with load on deck (if allowed)
- quadrants of operation
- level crane
- use of outriggers/stabilizers
- reference to load chart

1.2 Explain the safe and correct operation of a crane with a load.

Must include

- booming up and booming down
- telescoping in and out
- swinging/slewing clockwise and counter clockwise
- hoisting up and down
- travel on site (if allowed)
- picking and placing a load accurately and smoothly
- quadrants of operation
- level crane
- use of outriggers/stabilizers
- reference to load chart

Task 2

Demonstrate knowledge of safe control of the load.

Performance standards

2.1 Describe weather conditions and their effects on lifting.

Must include

- ice
- cold temperatures
- wind
- lightning storm
- poor visibility due to environmental conditions

2.2 Demonstrate techniques to maintain control of the hook block.

Must include

- maintain even control
- swing and hoist speed
- tag lines
- load centre of gravity below boom tip

Task 3

Demonstrate knowledge of safely and efficiently moving and placing a load at its intended destination.

Performance standard

3.1 Describe procedures for moving and placing a load safely.

Must include

- obey signal person
- avoid all obstacles
- load properly rigged
- load line to remain vertical while load is being moved
- load is to be lifted and placed slowly to minimize dynamic loading
- smooth, controlled movement
- crane within capacity throughout the lift
- load safely supported before being removed from crane hook

Task 4

Demonstrate knowledge to monitor equipment performance and troubleshoot problems while using a crane.

Performance standards

4.1 Explain how to monitor equipment performance during operation.

Must include

- water levels
- oil fluid levels
- hydraulic levels
- instrument gauges

4.2 Explain how to troubleshoot equipment problems according to manufacturer's specifications.

Task 5

Demonstrate knowledge of hoisting procedures.

Performance standards

5.1 Demonstrate knowledge of hoisting procedures.

Must include

- critical lifts
- multi-crane lifts
- suitable rigging
- hoisting from lower to higher capacity quadrants

5.2 Explain pick and carry procedures, if permitted by manufacturer.

Must include

- travel slow speed
- shortest boom length possible
- load as low as possible
- boom oriented as specified by the manufacturer
- load restrained from swinging

5.3 Describe procedures for operating in the vicinity of high voltage equipment according to local utility authority and limits of approach.

Must include

- safety watcher
- assurance in writing
- critical lifts (lifting over lines)

5.4 Describe procedures for doing a blind lift.

Must include

- use of radio when signal person not visible
- use of second signal person when one is not visible

5.5 Describe procedures for hoisting personnel.

Must include

- procedures outlined in WorkSafeBC regulations

5.6 Describe procedures for moving a load as part of a multi-crane lift / critical lift.

Must include

- lift plan
- lift plan meeting
- rigging plan
- requirement for supervision by someone other than one of the crane operators.

Task 6

Demonstrate knowledge of post-operational procedure.

Performance standards

6.1 Remove all loads/rigging from hook and raise hook.

6.2 Ensure boom is in safe position.

6.3 Clean wheels/tracks and attachments.

6.4 Ensure equipment is in the appropriate location and is safely parked.

6.5 Shut down equipment correctly.

6.6 Safely secure equipment.

Must include

- lock up
- disconnect battery

6.7 Perform housekeeping tasks.

Must include

- deck is clean
- cab is clean
- rubbish/obstacles in cab is removed

6.8 Perform post-operation inspection.

Must include

- fluid levels
- shutdown
- lock up
- appropriate location

C. Cranes

Unit Standard C7u K

Demonstrate knowledge of regulatory requirements pertaining to cranes

Purpose

Demonstrate knowledge of the regulations to legally and safely operate cranes.

Task 1

Demonstrate knowledge of how the regulations apply to the operation of cranes in a workplace.

Performance standard

1.1 Explain the impact of current regulations on workplace practices and crane operations.

Must include

- WorkSafeBC Occupational Health and Safety Regulation (OHSR)
- CAN/CSA-Z150-20 Safety Code for Mobile Cranes
- ANSI Standard ANSI/ASME B30.5-2021, Mobile and Locomotive Crane or ANSI/ASME B30.22-2016, Articulating Boom Crane

C. Cranes

Unit Standard C10u K

Demonstrate knowledge of crane components and attachments for mobile hydraulic cranes 20 tonnes (22.05 US tons) and under

Purpose

Demonstrate knowledge of crane components and attachments.

Task 1

Demonstrate knowledge of carriers and undercarriages.

Performance standards

1.1 Identify and describe the purpose of carrier, truck and undercarriage components.

Must include

- suspension
- wheels
- tires
- crawlers/tracks
- counterweight
- hydraulic motors

1.2 Describe defects and malfunctions that can occur on the carrier, truck and undercarriage.

Must include

- cracked frame
- cracked welds
- broken drive line shafts
- damaged wheels
- damaged differentials
- tires
- loose/broken fasteners, bolts, washers

Task 2

Demonstrate knowledge of outrigger and stabilizing equipment.

Performance standard

2.1 Identify and describe the functions of outrigger and stabilizing equipment.

Must include

- outrigger beams
- outrigger jacks
- outrigger pads
- retaining pins for outrigger pads
- hydraulic hoses
- holding valves
- correct outrigger beam extension and marking(s)
- maintenance

Task 3

Demonstrate knowledge of the turntable and turret on a variety of mobile cranes.

Performance standards

3.1 Identify components of a turntable and turret and describe their functions.

Must include

- bearings
- bolts
- gears
- swing gear

3.2 Describe defects and malfunctions of the turntable or turret components.

Must include

- loose, cracked, missing bolts and/or incorrect bolts
- structural cracks
- damage to the turntable or turret
- gear wear
- bearing wear
- missing washers
- deformation

Task 4

Demonstrate knowledge of attachments for mobile cranes.

Performance standards

4.1 Identify and describe attachments for mobile cranes above the hook.

Must include

- boom extensions
- jibs
- block/ball

4.2 Identify and explain functions for attachments.

Must include

- boom extensions
- jibs
- block/ball

4.3 Describe defects or malfunctions of an attachment.

Must include

- boom extensions
- jibs
- block/ball (cracks, deformation, wear, etc.)

Task 5

Demonstrate knowledge of suspended/pinned work platforms.

Performance standard

5.1 Identify and describe operating requirements of suspended/pinned work platforms.

Must include

- trial lift
- safety factor of rigging
- fall protection requirements
- crane to be downrated when lifting personnel (safety factor required)
- platforms must be engineered to meet standard
- anti-two block system
- critical lift requirements

Task 6

Demonstrate knowledge of crane safety components, devices and aids.

Performance standards

6.1 Identify safety devices and aids and describe their functions.

Must include

- load monitoring and indicating systems
- anti-two block device
- boom length indicator
- boom angle indicator
- level indicator
- drum rotation indicator

6.2 Introduce crane operator aids and describe their functions.

Must include

- load charts
- range diagrams
- lifting area charts
- crane operators' manuals
- crane logbook

6.3 Explain overload prevention systems e.g. rate capacity limit (RCL), rate capacity indicator (RCI), load moment indicator (LMI).

6.4 Describe defects or malfunctions of safety devices, components and aids.

Must include

- load monitoring and indicating systems
- anti-two block device
- boom length indicator
- boom angle indicator
- level indicator
- drum rotation indicator

6.5 Explain actions to take when safety devices malfunction.

Must include

- report to supervisory personnel
- enter in crane logbook
- suspend crane operations if necessary
- repair
- enter repair in crane logbook

C. Cranes

Unit Standard C13u K

Demonstrate knowledge of pre-operational requirements in mobile hydraulic crane 20 tonnes (22.05 US tons) and under operations

Purpose

This unit provides the knowledge required to do a pre-operational inspection in accordance with manufacturer's recommendations, the relevant standard and the Occupational Health and Safety Regulation (OHSR).

Task 1

Demonstrate knowledge of the pre-operational inspection procedures recommended for a mobile crane.

Performance standards

1.1 Explain inspection procedures accurately.

Must include

- operator aids for crane in place
- WorkSafeBC Occupational Health and Safety Regulation (OHSR) and requirements followed
- manufacturer's specifications are followed
- control and safety devices

1.2 Identify and describe the location and verification of operator aids for the crane.

Must include

- load monitoring and indicating system
- boom length indicator (if applicable)
- boom angle indicator (if applicable)
- load radius indication (as part of LMI system)

1.3 Explain the completion and filing of inspection reports.

Must include

- crane logbook

Task 2

Demonstrate knowledge of tests, repairs and maintenance required during the pre-operation inspection stage.

Performance standards

2.1 Describe function tests on hoist systems.

Must include

- boom up
- boom down
- hoist up
- hoist down
- swing left
- swing right
- retract boom
- extend boom
- brakes

2.2 Explain service and maintenance prior to operation according to manufacturer's specifications and enter them in the crane logbook.

Task 3

Demonstrate knowledge of reports and records required for reporting deficiencies or defects.

Performance standards

3.1 Explain the process of accurately reporting defects and deficiencies to the supervisor and properly documenting them in the crane logbook.

Must include

- date
- description of issue
- signature of person identifying the issue
- legal requirements entries must meet WorkSafeBC regulations, and any other applicable regulatory agencies codes, laws and guidelines

3.2 Explain the process to ensure repairs and maintenance are recorded in the appropriate crane logbook.

Must include

- date
- description of repair or maintenance
- signature of person performing maintenance or repairs

Task 4

Demonstrate knowledge of the setup procedures for mobile cranes.

Performance standards

4.1 Explain setup procedures accurately according to manufacturer's specifications, the relevant standard and the Occupational Health and Safety Regulation (OHSR).

Must include

- site assessment

4.2 Identify and describe obstructions.

Must include

- electrical power lines
- trees

4.3 Identify and describe bearing surface hazards.

Must include

- underground services
- underground building structures
- soil/support bearing capacity

4.4 Explain the requirements for blocking and mats to be sufficient considering the load requirements and surface conditions to level the crane.

Must include

- soil types
- calculation of bearing pressure
- estimation of outrigger loads
- blocking requirements
- blocking methods

4.5 Program and adjust safety devices to ensure accuracy and safety while lifting.

Must include

- load monitoring and indicating system
- anti-two block systems
- boom angle indicators

4.6 Level the crane.

Must include

- spirit levels
- plumb load line
- equal load on all outriggers

C. Cranes

Unit Standard C14u K

Demonstrate knowledge of power transfer for mobile cranes

Purpose

Demonstrate knowledge of power transfer including pneumatic, hydraulic, electrical, steering and braking.

Task 1

Demonstrate knowledge of pneumatic systems in crane operations.

Performance standards

1.1 Identify components of pneumatic systems and describe their functions.

Must include

- air brakes
- horn
- air control levers

1.2 Describe defects or malfunctions of pneumatic systems.

Must include

- air brakes
- horn
- air control levers

Task 2

Demonstrate knowledge of hydraulic systems in crane operations.

Performance standards

2.1 Identify components of hydraulic systems and describe their functions.

Must include

- hydraulic fluid
- filters
- lines
- pumps
- motors
- fittings
- hydraulic control levers

2.2 Describe defects or malfunctions of hydraulic systems.

Must include

- hydraulic fluid
- filters
- lines
- pumps
- motors
- fittings
- hydraulic control levers

Task 3

Demonstrate knowledge of electrical systems in crane operations.

Performance standards

3.1 Identify components of electrical systems and describe their functions.

Must include

- alternator
- starter
- wiring
- fuses
- electric motor
- limit switches

3.2 Describe defects or malfunctions of electrical systems.

Must include

- alternator
- starter
- wiring
- fuses
- electric motor
- limit switches

Task 4

Demonstrate knowledge of steering system components in crane operations.

Performance standards

4.1 Identify components of steering systems and describe their functions.

Must include

- axles
- tie rods
- steering box
- ball joints

4.2 Describe defects or malfunctions of steering systems.

Must include

- axles
- tie rods
- steering box
- ball joints

C. Cranes

Unit Standard C17u K

Demonstrate knowledge to leave a mobile hydraulic crane 20 tonnes (22.05 US tons) and under unattended

Purpose

This unit provides the knowledge required to leave a crane unattended for short or long periods of time.

Task 1

Demonstrate knowledge to leave a crane unattended for short periods of time

Performance standards

- 1.1 Describe the procedure for leaving a crane unattended for short periods of time (lunch breaks etc.)

Must include

- lower the load and remove the rigging
- raise hook
- apply brakes
- apply dogs (if applicable)
- leave in working position
- turn off ignition and remove the key

- 1.2 Describe the procedure for leaving a crane unattended for long periods of time (overnight, weekends, etc.)

Must include

- lower the load and remove the rigging
- boom down on blocking or in cradle
- apply brakes
- apply dogs (if applicable)
- attachment on the ground
- turn off ignition and remove the key
- lock the doors

Task 2

Demonstrate knowledge of the shutdown procedures for a mobile crane.

Performance standards

- 2.1 Describe procedures for cleaning wheels/tracks and attachments.

2.2 Describe the safe parking of equipment in the appropriate location.

2.3 Describe correct shutdown of equipment.

2.4 Describe procedures for safely securing the equipment.

Must include

- lock up
- disconnect battery / night switches

2.5 Describe housekeeping tasks.

Must include

- keep deck clean
- keep cab clean

C. Cranes

Unit Standard C20u W

Demonstrate the use of crane components and attachments for mobile hydraulic cranes 20 tonnes (22.05 US tons) and under in the workplace

Purpose

Apply knowledge of crane components and attachments.

Task 1

Apply knowledge of carriers and undercarriages in pre-operational inspection.

Performance standards

- 1.1 Perform a pre-operational inspection of the carrier, truck and undercarriage components.

Must include

- suspension
- wheels
- tires

- 1.2 Identify and describe defects and malfunctions that can occur on the carrier, truck and undercarriage.

Must include

- cracked frame
- cracked welds
- broken drive line shafts
- damaged wheels
- damaged differentials
- tires
- loose/broken fasteners, bolts, washers

Task 2

Apply knowledge of outriggers and stabilizing equipment during a pre-setup inspection.

Performance standard

- 2.1 Identify and explain the functions of outrigger and stabilizing equipment.

Must include

- outrigger beams
- outrigger jacks
- outrigger pads
- retaining pins
- hydraulic hoses
- holding valves
- correct outrigger beam extension and marking(s)
- maintenance

Task 3

Work with the turntable and turret on a variety of mobile cranes.

Performance standards

3.1 Identify components of a turntable and turret and describe their functions..

Must include

- bearings
- bolts
- gears

3.2 Describe defects and malfunctions of the turntable or turret components.

Must include

- loose bolts
- structural cracks
- damage to the turntable or turret
- gear wear
- bearing wear

Task 4

Demonstrate the use of above the hook and below the hook attachments for mobile cranes.

Performance standards

4.1 Identify applicable attachments for mobile cranes.

Must include

- boom extensions
- jibs

4.2 Identify and describe applicable functions for attachments.

Must include

- boom extensions
- jibs
- demonstrate how to attach a jib

4.3 Describe defects or malfunctions of an applicable attachment.

Must include

- boom extensions
- jibs

Task 5

Demonstrate the use of suspended/pinned work platforms.

Performance standard

5.1 Identify and describe operating requirements of suspended/pinned work platforms.

Must include

- trial lift
- safety factor of rigging
- fall protection requirements
- crane to be downrated when lifting personnel (safety factor required)
- platforms must be engineered to meet standard
- anti-two block system
- critical lift requirements

Task 6

Demonstrate the use of crane safety components, devices and aids.

Performance standards

6.1 Identify safety component devices and aids and describe their functions.

Must include

- load monitoring and indicating systems
- anti-two block devices (when winch is installed)
- boom length indicators
- boom angle indicator
- level indicator
- drum rotation indicator

6.2 Demonstrate crane operator aids and their functions.

Must include

- load charts
- range diagrams
- lifting area charts
- crane operators' manuals
- crane logbook

6.3 Describe defects or malfunctions of safety devices, components and aids.

Must include

- load monitoring and indicating systems
- anti-two block devices (when winch is installed)
- boom length indicators (if applicable)
- boom angle indicator
- level indicator
- drum rotation indicator

6.4 Explain actions to be taken when safety devices malfunction.

Must include

- report to supervisory personnel
- enter in crane logbook (date and sign)
- suspend crane operations if necessary
- repair faulty device
- record repair in crane logbook

C. Cranes

Unit Standard C23u W

Conduct pre-operational inspections of mobile hydraulic cranes 20 tonnes (22.05 US tons) and under in the workplace

Purpose

This workplace standard describes what an operator should be able to demonstrate in order to accomplish a pre-operational inspection in accordance with applicable regulations and manufacturer's specifications.

Task 1

Demonstrate knowledge of the pre-operational inspection procedures recommended for a mobile crane.

Performance standards

1.1 Explain inspection procedures accurately.

Must include

- operator aids for crane in place
- inspection reports are completed
- WorkSafeBC Occupational Health and Safety Regulation (OHSR) and requirements followed
- manufacturer's specifications are followed

1.2 Identify and describe the location and verification of operator aids for the crane.

Must include

- load monitoring and indicating system
- boom length indicator (if applicable)
- boom angle indicator (if applicable)
- load radius
- anti-two block
- crane manual
- load charts
- range diagram
- work area diagram

Task 2

Perform tests, repairs and maintenance required during the pre-operation inspection.

Performance standards

2.1 Perform a function test of operating controls.

Must include

- boom up
- boom down
- hoist up
- hoist down
- swing left
- swing right
- retract boom
- extend boom
- brakes

2.2 Complete repairs and maintenance prior to operation according to manufacturer's requirements and enter them in the crane logbook.

Task 3

Demonstrate the use of reports and records required for reporting deficiencies or defects.

Performance standard

3.1 Report defects and deficiencies accurately to the supervisor and properly document them in the crane logbook.

Must include

- date
- description of defect/deficiency
- signature of operator
- description of the repair effected
- signature of person doing the repairs
- legal requirements entries must meet WorkSafeBC regulations and any other applicable regulatory agency codes, laws and guidelines

Task 4

Conduct the setup procedures for a mobile crane.

Performance standards

4.1 Complete setup procedures accurately according to manufacturer's specifications and Occupational Health and Safety Regulation (OHSR).

4.2 Identify and describe overhead obstructions and underground hazards.

Must include

- electrical power lines
- trees
- underground services
- underground parking/space structures
- other equipment or structures

4.3 Describe the requirements for blocking and mats to be sufficient considering the load requirements and surface conditions to level the crane.

4.4 Program and adjust safety devices to ensure accuracy and safety while lifting.

Must include

- load monitoring and indicating system
- anti-two block systems
- boom angle indicators

C. Cranes

Unit Standard C26u W

Operate a mobile hydraulic crane 20 tonnes (22.05 US tons) and under safely

Purpose

This unit demonstrates the use of mobile cranes to pick up and carry loads in a safe and efficient manner in accordance with the manufacturer's recommendations.

Task 1

Correctly operate a crane with and without a load according to manufacturer's specifications.

Performance standards

1.1 Safely and correctly operate a crane without a load

Must include

- proper setup
- booming up and booming down
- swinging clockwise and counter clockwise
- hoisting up and down
- travel on site (if allowed with boom out of stowed position)
- quadrants of operation
- backward stability consideration

1.2 Safely and correctly operate a crane with a load

Must include

- proper setup
- booming up and booming down
- swinging clockwise and counter clockwise
- hoisting up and down
- travel on site (pick and carry if allowed)
- picking and placing a load accurately and smoothly
- quadrants of operation
- backward stability consideration

Task 2

Adjust procedures according to conditions and maintain safe control of the hook block.

Performance standards

2.1 Perform adjustments for weather conditions (may be performed in a simulated environment).

Must include

- ice (moving crane)
- cold temperatures
- load frozen to the ground
- high winds
- lightning storm
- poor visibility

2.2 Demonstrate techniques to maintain control of the hook block.

Must include

- maintain even control
- use slower swing speeds
- boom tip over the load centre of gravity
- load line vertical

Task 3

Perform hoisting procedures for a mobile crane following manufacturer's recommendations and following all safety regulations.

Performance standards

3.1 Demonstrate pick and carry procedures (if allowed).

Must include

- travel slow speed
- shortest boom length possible
- load as low as possible
- boom oriented as specified by the manufacturer
- load restrained from swinging

3.2 Demonstrate procedures for safely operating in the vicinity of high voltage equipment according to local utilities and limits of approach in a simulated environment.

3.3 Perform a blind lift safely.

Must include

- use of radio when signal person not visible
- use of second signal person when one is not visible

3.4 Perform a lift of a crane suspended work platform.

Task 4

Monitor equipment performance and troubleshoot problems while using a crane.

Performance standards

4.1 Demonstrate how to monitor equipment performance.

Must include

- water levels
- oil fluid levels
- hydraulic levels
- instrument gauges

4.2 Demonstrate procedures for troubleshooting equipment problems according to manufacturer's specifications.

Task 5

Safely and efficiently move and place loads at their intended destination.

Performance standard

5.1 Move and place a load safely.

Must include

- obey signal person
- avoid all obstacles
- load properly rigged
- smooth, controlled movement
- crane within capacity throughout the lift
- load safely supported before being removed from crane

C. Cranes

Unit Standard C29u W

Leave a mobile hydraulic crane 20 tonnes (22.05 US tons) and under unattended

Purpose

This unit demonstrates the requirements to leave a crane unattended for short or long periods of time in accordance with the manufacturer's recommendations.

Task 1

Leave a crane unattended for short and long periods of time

Performance standards

- 1.1 Safely and correctly leave a crane unattended for short periods of time (lunch breaks etc.)

Must include

- no load is on the hook
- hook is raised
- turn off and remove key
- swing brake applied
- swing dogs applied (if applicable)
- leave in working position

- 1.2 Safely and correctly leave a crane unattended for long periods of time (overnight, weekends, etc.)

Must include

- no load is on the hook
- boom down on blocking or in cradle
- turn off and remove the key
- swing brake applied
- swing dogs applied (if applicable)

Task 2

Perform the shutdown procedures for a mobile crane.

Performance standards

- 2.1 Thoroughly clean wheels/tracks and attachment according to company requirements.
- 2.2 Safely park crane equipment in the appropriate location.

2.3 Shut down the equipment safely and correctly.

2.4 Safely secure the equipment.

Must include

- lock up
- disconnect battery / night switch

2.5 Perform housekeeping tasks according to the company's standard requirements.

Must include

- keep deck clean
- keep cab clean
- remove rubbish/obstacles in cab

2.6 Perform a post-operation inspection.

Must include

- fluid levels
- shutdown
- lock up
- appropriate location

OPERATOR STANDARDS

SECTION D

RIGGING AND LIFTING THEORY

D. Rigging and Lifting Theory

Unit Standard D1u K

Demonstrate knowledge of lifting theory and forces

Purpose

Demonstrate knowledge of the fundamentals of leverage.

Task 1

Demonstrate knowledge of the principles of leverage.

Performance standard

1.1 Explain the principles of leverage.

Must include

- class 1 lever
- class 2 lever
- class 3 lever
- centre of gravity

D. Rigging and Lifting Theory

Unit Standard D2u K

Demonstrate knowledge of slings (all types), rigging hardware, materials, inspection and capacity cards

Purpose

Demonstrate knowledge of slings, rigging hardware, materials and manuals to safely lift a load.

Task 1

Demonstrate knowledge of slings and rigging hardware used in crane operations.

Performance standards

1.1 Identify slings and rigging hardware and describe their uses.

Must include types of slings

- wire rope (construction used in manufacturing)
- chain (grade of steel)
- synthetic web slings (types and material used in manufacturing)
- synthetic round slings (types and material used in manufacturing)

Must include types of hardware

- hooks
- shackles
- eyebolts
- wedge sockets

Must include types of hitch configurations

- vertical
- choker
- basket
- bridles

Must include below the hook lifting devices

- spreader bars
- equalizer beams
- pallet forks
- drywall lifters

1.2 Describe and accurately interpret specific information on slings and rigging hardware from manufacturer's and rigging manuals according to industry standards.

Task 2

Demonstrate knowledge to assemble appropriate rigging for a given load according to manufacturer's ratings and to ensure the load can be lifted safely.

Performance standards

2.1 Select appropriate slings and rigging hardware for a given lift.

Must include

- determining load weight
- calculating Working Load Limit (WLL) of slings and rigging hardware required
- sling and rigging hardware angle loading is calculated

2.2 Select the correct hitch and sling arrangement.

Must include

- use of correct hitch configuration
- reduction of sling WLL when used at an angle

Task 3

Demonstrate knowledge to inspect slings and rigging hardware.

Performance standards

3.1 Explain the procedure for inspecting slings and rigging hardware as per manufacturer's manuals and WorkSafeBC regulations.

3.2 Describe requirements for examining slings and rigging hardware.

Must include

- excessive wear
- damage
- cracks
- missing safety clips
- broken wires
- labelling

Task 4

Demonstrate knowledge to remove slings and rigging hardware from use.

Performance standards

4.1 Explain criteria for removing slings and rigging hardware from service according to appropriate WorkSafeBC regulations and as per manufacturer's specifications.

4.2 Explain the process for removing slings and rigging hardware.

Must include

- remove from service if repair is not allowed
- destroy rejected rigging

4.3 Report defects to appropriate personnel.

Task 5

Demonstrate knowledge to store slings and rigging hardware after use.

Performance standard

5.1 Explain criteria for storing slings and rigging hardware as per good practice.

D. Rigging and Lifting Theory

Unit Standard D3u K

Demonstrate knowledge of wire rope hoist line construction and inspection

Purpose

Demonstrate knowledge of wire rope used in crane operations.

Task 1

Describe types of wire rope used in crane operation.

Performance standard

- 1.1 Identify types of wire rope used for hoisting and describe their characteristics, classifications and uses.

Must include

- conventional construction wire rope
- anti-rotational wire rope
- Seale construction
- filler construction
- Working Load Limit (WLL) of wire rope used in hoisting operations
- breaking strength vs. working load limit

Task 2

Demonstrate knowledge of the process for inspection and replacement of wire ropes in accordance with manufacturer's recommendations.

Performance standards

- 2.1 Explain the inspection and examination procedure for wire rope defects.

Must include

- lubrication
- excessive wear
- bird caging
- kinking
- flattening
- proper spooling
- broken wires
- distortion

- 2.2 Explain the rejection criteria for damaged or defective rope according to WorkSafeBC regulations and manufacturer's specifications.

- 2.3 Explain the process to examine the drum to ensure proper installation.
- 2.4 Explain the process to record and report the inspection defects and deficiencies.

Must include

- record inspection in logbook
- record defects in logbook
- report defects to supervisory personnel

Task 3

Demonstrate knowledge of installing wire rope on a winch according to manufacturer's instructions.

Performance standards

- 3.1 Explain wire rope installation process according to manufacturer's requirements.

Must include

- procedure for installing new wire rope on a winch
- winding direction
- proper spooling on drum

- 3.2 Identify and describe wire rope system components.

Must include

- rope guides
- drums
- blocks
- hooks
- sheaves
- wedge and socket termination
- installing wedge sockets
- reeving multi-part line blocks

Task 4

Demonstrate knowledge of how to store wire rope.

Performance standard

- 4.1 Explain the criteria for storing wire rope according to manufacturer's requirements.

Task 5

Demonstrate knowledge of how to maintain wire rope.

Performance standards

5.1 Explain criteria for lubricating wire rope.

Must include

- inspection of rope
- identifying rope needing lubrication

5.2 Explain procedures to perform maintenance on wire ropes as manufacturer dictates.

Must include

- cutting and seizing wire ropes
- cleaning
- lubrication

5.3 Record wire rope maintenance in the logbook within the regulated timeframe.

D. Rigging and Lifting Theory

Unit Standard D4u W

Use slings (all types), rigging hardware, materials and capacity cards in the workplace

Purpose

This unit standard allows the trainee to demonstrate the knowledge gained by performing rigging activities in the workplace.

Task 1

Assemble appropriate rigging for a given load to comply with Occupational Health and Safety Regulation (OHSR).

Performance standard

1.1 Select and use appropriate slings and rigging hardware for various lifts.

Must include

- measure load
- calculate weight of load
- calculate sling requirements
- calculate hardware requirements
- reduction of WLL due to sling angle and type of hitch
- wear protective equipment
- attach slings to load to prevent slipping

Task 2

Inspect, maintain and store slings and rigging hardware in workplace operations.

Performance standard

2.1 Inspect, maintain and store slings and rigging hardware according to manufacturer and company specifications.

OPERATOR STANDARDS

SECTION E

HOISTING FUNDAMENTALS

E. Hoisting Fundamentals

Unit Standard E1u K

Demonstrate knowledge of determining load weights using fundamental math functions and calculations

Purpose

This unit provides the basis for determining load weights for given lifts by using fundamental math functions and calculations.

Note

A scientific calculator is required for this unit.

Task 1

Demonstrate the functions of a scientific calculator to perform mathematical calculations.

Performance standards

1.1 Perform fundamental mathematical functions.

Must include

- rounding off
- fractions
- metric and imperial units of measure
- circumference of a circle
- perimeter of an object
- surface area of an object
- Pythagorean theorem

Task 2

Demonstrate knowledge of accurately calculating load weights.

Performance standard

2.1 Determine accurate load weights.

Must include

- volume of an object
- weight of a cubic unit of an object
- weight of materials
- total weight of load

Task 3

Demonstrate ability to interpret engineering and worksite documentation.

Performance standards

3.1 Interpret lift plans accurately.

Must include

- capacity
- boom configuration
- load weight
- rigging weight
- calculations
- radius of crane
- positioning of crane
- positioning of the load

3.2 Compare shipping company's bill of lading to a calculated weight based on volume, load indicating and monitoring system and type of load to determine accuracy.

3.3 Interpret load capacity charts accurately.

Must include

- gross capacity
- net capacity
- structural capacities
- stability capacities
- operating notes
- capacities between listed chart values
- quadrants of operation
- outrigger position
- deductions from gross capacity
- operating radius
- boom length
- boom angle
- main boom capacities
- jib capacities
- range diagrams
- permissible line pull
- load chart symbols

E. Hoisting Fundamentals

Unit Standard E4u K

Demonstrate knowledge of load charts and load calculations for mobile hydraulic cranes 20 tonnes (22.05 US tons) and under

Purpose

This unit provides the knowledge required to operate a mobile hydraulic crane 20 tonnes (22.05 US tons) and under to lift and place loads in a safe and efficient manner.

Task 1

Demonstrate knowledge of load charts.

Performance standards

- 1.1 Interpret load charts accurately.
- 1.2 Verify load dimensions with crane supervisor (and engineer as required).
- 1.3 Identify and describe special lift instructions.

Task 2

Demonstrate knowledge of lift plans.

Performance standard

- 2.1 Interpret lift plans

Must include

- capacity
- boom configuration
- load weight
- rigging weight
- calculations
- radius of crane
- positioning of crane
- positioning of the load

E. Hoisting Fundamentals

Unit Standard E7u W

Interpret load charts and load study drawings to configure a mobile hydraulic crane 20 tonnes (22.05 US tons) and under for workplace operation

Purpose

This unit allows for the demonstration of correct crane configuration based on load charts and load study drawings.

Task 1

Configure crane appropriately after accurately interpreting load charts and lift plan drawings.

Performance standards

- 1.1 Interpret load charts accurately.
- 1.2 Verify load dimensions with crane supervisor (and engineer as required).
- 1.3 Determine centre of gravity of load.
- 1.4 Follow special lift instructions.

Task 2

Interpret lift plans accurately.

Performance standard

- 2.1 Interpret lift plans.

Must include

- capacity
- boom configuration
- load weight
- rigging weight
- calculations
- radius of crane
- positioning of crane
- positioning of the load

OPERATOR STANDARDS

SECTION F

TRANSPORTATION AND/OR TRAVEL

F. Transportation and/or Travel

Unit Standard F1u K

Demonstrate knowledge of BC Ministry of Transportation – Commercial Transport rules and regulations

Purpose

This unit provides the knowledge required to prepare a mobile crane for transport and/or travel in accordance with the BC Ministry of Transportation – Commercial Transport regulations.

Task 1

Demonstrate knowledge of legislation and regulations to travel or transport a crane on public highways according to the BC Ministry of Transportation - Commercial Transport Regulations.

Performance standards

- 1.1 Locate and explain related sections of the BC Ministry of Transportation - Commercial Transport Regulations for the travel and transportation of boom trucks, mobile cranes and components.
- 1.2 Explain criteria for special permits for travel or transportation of a crane on a public highway.

Must include

- overall height
- overall weight
- overall length
- total axle weight

F. Transportation and/or Travel

Unit Standard F4u K

Demonstrate knowledge to prepare a mobile hydraulic crane 20 tonnes (22.05 US tons) and under for transport and/or travel

Purpose

This unit provides the knowledge to prepare a mobile crane for transport and/or travel.

Task 1

Demonstrate knowledge of preparing a crane and components for highway travel in accordance with manufacturer's recommendations and the BC Ministry of Transportation - Commercial Transport Regulations.

Performance standards

1.1 Explain the requirements to prepare a mobile crane for transport and/or travel.

Must include

- flags
- lights
- permits

1.2 Describe the structural integrity and capacity to transport the crane and components.

Must include

- weight carrying capacity
- glad hands
- electrical connections
- inspection stickers
- permits

1.3 Explain the procedures to prepare a mobile crane for transport and/or travel.

Must include

- swing/away lattice extension stowed
- retract the boom
- lower boom into cradle
- apply swing brake and house lock (if applicable)
- secure hook to tie down (if applicable)
- retract and pin outrigger beam
- remove outrigger pads

1.4 Explain requirements to safely load and secure a crane and components on a transporter displaying correct and serviceable signage and signals.

Must include

- manufacturer's procedures
- BC Ministry of Transportation - Commercial Transport Regulations
- flags
- flashers
- warning signs

F. Transportation and/or Travel

Unit Standard F5u W

Prepare a mobile crane for transport and/or travel to a worksite following all highway and traffic rules and regulations

Purpose

This unit provides the demonstration of skills required to prepare a mobile crane for transport and/or travel to a worksite.

Task 1

Prepare rubber-tired cranes and components for highway travel following manufacturer's recommendations and the BC Ministry of Transportation - Commercial Transport Regulations.

Performance standard

- 1.1 Safely prepare the crane and components for transport and/or travel, displaying correct and serviceable signage and signals.

Must include

- manufacturer's recommendations
- BC Ministry of Transportation - Commercial Transport Regulations
- security of components
- flags
- flashers
- warning signals
- permit verification

OPERATOR STANDARDS

SECTION G

SITE PLANNING AND CRANE POSITIONING

G. Site Planning and Crane Positioning

Unit Standard G1u K

Demonstrate knowledge of site assessment tools

Purpose

This unit provides the knowledge required to assess a site accurately in order to operate a mobile crane.

Task 1

Demonstrate knowledge of lift plans.

Performance standards

1.1 Explain the purpose of site plans and engineering drawings in preparing lift plans.

Must include

- placement of load
- placement of crane
- grade to be travelled on
- structural integrity of the area
- ground bearing capacity of the area

1.2 Describe the elements of a standard lift plan.

Must include

- routine to move load
- determine that the crane has the capacity required to pick, move and place the load
- maximum allowable travel grade according to crane manufacturer specifications
- walk travel path first to evaluate hazards
- signal person
- rigging required
- horn or backup alarm
- signed by operator
- signed by supervisor
- critical lift
- tandem lift

G. Site Planning and Crane Positioning

Unit Standard G2u K

Demonstrate knowledge of safely locating and positioning a crane

Purpose

This unit provides the knowledge required to safely locate and position a crane.

Task 1

Demonstrate knowledge to establish the location of a crane on a work site.

Performance standards

1.1 Explain site conditions and hazard assessment.

Must include

- accessibility of site
- grade of site
- soil conditions and compaction
- distance to embankments or excavations
- initial location of load
- final placement of load
- proximity of other equipment or structures
- overhead obstructions
- distance to electrical power lines
- tail swing distance
- determine actual and potential underground hazards
- weather conditions
- walk travel path to evaluate hazards

1.2 Explain load placement considerations and potential hazards.

Must include

- initial location of load
- load path
- final placement of load
- proximity of other equipment or structures
- overhead obstructions
- distance to electrical power lines
- known underground hazards
- weather conditions

Task 2

Demonstrate knowledge of blocking to be used according to soil conditions.

Performance standards

2.1 Explain blocking requirements according to soil types.

2.2 Explain criteria for proper blocking methods.

Task 3

Demonstrate knowledge of communication required during crane and load positioning.

Performance standard

3.1 Describe requirements for communications during crane and load positioning.

Must include

- signal persons (line of sight)
- radio communications (blind, multi-crane or poor visibility)
- traffic control

Task 4

Demonstrate knowledge of barriers and signage required in a worksite.

Performance standard

4.1 Describe requirements for barriers and signage.

Must include

- clearance between the tailswing of crane and any fixed object
- traffic control
- pedestrian
- audible warning when lifting overhead

Task 5

Demonstrate knowledge of grounding and bonding of a crane at a worksite.

Performance standard

5.1 Explain procedures and requirements for grounding and bonding of a crane at a worksite according to local power authority requirements.

G. Site Planning and Crane Positioning

Unit Standard G3u W

Conduct an accurate site assessment and safely position a crane in the workplace

Purpose

This unit provides demonstration of conducting a site assessment and locating and safely positioning a crane.

Task 1

Inspect a site and develop an accurate lift plan using site plan and an engineered drawing.

Performance standards

1.1 Develop an accurate lift plan.

Must include

- assessment of area and soil condition
- assessment of hazards
- assessment of obstacles
- overhead hazards
- underground utilities
- walk travel path
- traffic control established
- load weight
- rigging required, rigging weight, rigging certified
- lift supervisor or signal person competent
- determine the load is within the crane's capacity throughout the lift
- critical lift
- tandem lift

1.2 Locate and position a crane safely and correctly.

Must include

- blocking and blocking mats
- signalling and barrier signage
- grounding

OPERATOR STANDARDS

SECTION I

MAINTENANCE AND SERVICE

I. Maintenance and Service

Unit Standard I3u K

Demonstrate knowledge of inspecting engines, monitoring devices and hydraulic systems on mobile hydraulic cranes 20 tonnes (22.05 US tons) and under

Purpose

This unit provides the knowledge required to inspect engines, monitoring devices and hydraulic systems.

Task 1

Demonstrate knowledge of tools required to perform basic maintenance.

Performance standard

1.1 Identify the tools required for basic crane maintenance and describe their functions.

Must include

- grease gun
- hand tools
- hammers
- pry bar
- step ladder
- tape measure

Task 2

Demonstrate knowledge of inspecting engines on mobile cranes.

Performance standard

2.1 Explain engine inspections correctly.

Must include

- oil levels
- air filters
- radiator levels and coolant systems
- air dryer systems

Task 3

Demonstrate knowledge of inspecting monitoring devices on mobile cranes.

Performance standard

3.1 Explain inspection of monitoring and safety devices accurately.

Must include

- load monitoring and indicating system
- boom angle indicator
- boom length indicator
- anti-two block device
- load radius indicator
- level indicator
- drum rotation indicator

Task 4

Demonstrate knowledge of inspecting hydraulic systems on mobile cranes.

Performance standards

4.1 Explain safety precautions to take while performing inspections.

Must include

- discharge of pressure in system
- avoiding oil being injected into the bloodstream
- shutdown of motor
- avoiding burns and scalds

4.2 Explain hydraulic system inspection accurately.

Must include

- pumps
- fluid levels
- hoses
- motors
- valves

I. Maintenance and Service

Unit Standard I6u K

Demonstrate knowledge of servicing and maintenance procedures for mobile hydraulic cranes 20 tonnes (22.05 US tons) and under

Purpose

This unit provides the knowledge required to perform service and maintenance on mobile cranes.

Task 1

Demonstrate knowledge of engine cooling system maintenance information from manufacturer's manuals.

Performance standard

1.1 Explain the use and interpretation of manufacturers' manuals.

Task 2

Demonstrate knowledge of service and maintenance performed on mobile cranes.

Performance standards

2.1 Explain basic service and maintenance of crane engines.

Must include

- grease fittings (as per manufacturer's specifications)
- addition of required fluids
- adjustment of belts
- replacement of belts
- replacement of air cleaners
- oil and filter change
- hoses

2.2 Explain methods for the adjustment of control mechanisms.

Must include

- cables
- brakes
- clutches
- levers
- grease fittings

2.3 Explain structural maintenance.

Must include

- bolts
- cotter pins and keepers
- pins
- guard rails, handholds, steps
- tracks
- idlers
- grease

2.4 Explain cleaning procedures for crane components.

Must include

- batteries
- cab
- windows
- wheels
- deck

2.5 Explain service and maintenance procedures for crane and accessory systems.

Must include

- gearbox
- hydraulic tank breathers
- outriggers and stabilizers
- booms
- steering systems
- air tanks
- filters
- tire (condition and pressure)

2.6 Explain maintenance of cooling systems.

Must include

- air cooling systems
- water cooling systems

Task 3

Demonstrate knowledge of factors influencing operator's maintenance responsibilities.

Performance standard

3.1 Explain factors influencing operator's maintenance responsibilities.

Must include

- operator's responsibility
- operator's capabilities
- tool availability
- company policy
- location

Task 4

Demonstrate knowledge of reporting and recording procedures for mobile crane service and maintenance.

Performance standards

4.1 Explain procedures for reporting defects to supervisory personnel.

Must include

- part 4.9 of WorkSafeBC Occupational Health and Safety Regulation (OHSR) is reviewed

4.2 Explain procedures for recording maintenance and inspections in the equipment logbook.

Must include

- maintenance requested, when and by whom
- maintenance performed, when and by whom
- legal requirements for entries
- part 4.9 of WorkSafeBC Occupational Health and Safety Regulation (OHSR) is reviewed

I. Maintenance and Service

Unit Standard I9u W

Complete mobile hydraulic crane 20 tonnes (22.05 US tons) and under maintenance checklists (engine on/engine off) and maintain engines to manufacturer's specifications

Purpose

This unit provides the demonstration of engine maintenance according to manufacturer's specifications.

Task 1

Complete maintenance engine checklists while the engine is OFF.

Performance standards

- 1.1 Check all parts of the checklist accurately according to the company's requirements and manufacturer's manuals.
- 1.2 Identify problems accurately.
- 1.3 Record identified problems in the maintenance logbook.
- 1.4 Report identified problems to the crane superintendent.

Task 2

Complete maintenance engine checklists while the engine is ON.

Performance standards

- 2.1 Check all parts of the checklist accurately according to the company's requirements.
- 2.2 Identify problems accurately.
- 2.3 Record identified problems in the maintenance logbook.
- 2.4 Report identified problems to the crane superintendent.

Task 3

Maintain engines to the manufacturer's specifications.

Performance standards

- 3.1 Perform basic service and maintenance of crane engines.

Must include

- addition of required fluids
- adjustment of belts
- replacement of belts
- air cleaners
- oil filters
- hoses

3.2 Interpret manufacturer's manuals accurately to determine maintenance requirements.

3.3 Correctly use the tools required for basic crane maintenance.

Must include

- grease gun
- wrenches
- screwdrivers
- hammers
- vice grips
- shovels (track)
- pinch bar
- step ladder
- tape measure
- rags/wipes

3.4 Perform structural maintenance.

Must include

- bolts
- wedges
- cotter pins and keepers

3.5 Perform service and maintenance to crane and accessory systems.

Must include

- gearbox
- hydraulic tank breathers
- outriggers and stabilizers
- booms
- steering systems
- air tanks
- filters
- tires (condition and pressure)

3.6 Clean crane components.

Must include

- batteries
- cab
- windows
- wheels
- deck

I. Maintenance and Service

Unit Standard I10u W

Perform routine inspections and maintenance of hydraulic systems on mobile cranes

Purpose

This unit provides the demonstration of routine maintenance of hydraulic systems on mobile cranes.

Task 1

Perform routine inspections and maintenance of hydraulic systems on mobile cranes.

Performance standards

1.1 Inspect hydraulic systems accurately.

Must include

- pumps
- fluid levels
- hoses
- motors

1.2 Perform maintenance of hydraulic systems safely and correctly.

I. Maintenance and Service

Unit Standard I11u W

Maintain an equipment logbook to retain a permanent written record of maintenance and repairs

Purpose

Demonstrate the correct use of, and relevant input to, the crane equipment logbook.

Task 1

Record all inspections and maintenance in an equipment logbook.

Performance standards

- 1.1 Ensure all entries are legible and easily understood.
- 1.2 Record all entries completely and accurately.
- 1.3 Record all inspections accurately as and when inspection is completed.
- 1.4 Record all requests for maintenance and repairs accurately.
- 1.5 Accurately record all maintenance and repairs performed when and as completed.

Task 2

Report all inspections, defects, deficiencies, and maintenance required and performed to the crane supervisor and site supervisor.

Performance standards

- 2.1 Ensure communication is clear and understood.
- 2.2 Make reports at the time of the inspection, request or maintenance.

TRAINING PROVIDER STANDARDS

TRAINING PROVIDER STANDARDS

Instructor Qualification:

For technical training, instructors must be occupationally competent to run the crane type they are training to and, as a minimum, hold a BC Certificate of Qualification for that crane type.

Minimum List of Shop/Laboratory Equipment Required for Mobile Hydraulic Crane Under 20 Tonnes (22.05 US Tons)

Industry has not set minimum equipment requirements for providing training for this trade. Industry standards are focused on the outcomes of training rather than the inputs. It is left to the crane training community to deliver training that will meet these standards in a time efficient and cost effective manner. Training providers are permitted maximum flexibility in the options and strategies they may employ in training operators to meet these standards.

RECOMMENDED REFERENCE MATERIALS

From the Construction Safety Association of Ontario <http://www.csao.org/>

Mobile Crane Manual

by Donald E. Dickie, P. Eng., D. H. Campbell, P. Eng.

Construction Safety Association of Ontario..... ISBN 0-8273-6527-6

Rigging Manual

by Donald E. Dickie, P. Eng.

Construction Safety Association of Ontario..... ISBN 0-7726-1574-8

Hoisting and Rigging Safety Manual

Construction Safety Association of Ontario ISBN 0-919465-70-6

Slings

Construction Safety Association of Ontario ISBN 0-919465-76-5

Safety in Rigging Video/DVD Series

The complete set of 10 *Safety in Rigging* DVDs (FD001-FD010), complete with instructor's notes. Includes:

Cranes: Types, Components and Case Histories (FD001)

Hazard Awareness in Crane Operating Areas (FD002)

International Hand Signals (FD003)

Wire Rope (FD004)

Hardware (FD005)

Chain (FD006)

Slings (FD007)

Reeving (FD008)

Hoists, Winches and Related Devices (FD009)

Jacks, Rollers and Related Devices (FD010)

Cranes: Types, Components and Case Histories Video/DVD (set of 10)

From the Operating Engineers Training Institute of Ontario <http://www.oetio.com>

Mobile Craning Today
Operating Engineers Training Institute of Ontario ISBN 0-8273-5460-6

Additional Resources

IPT's Crane and Rigging Handbook
by Ronald G. Garby ISBN 0-920855-14-8

IPT's Crane and Rigging Training Manual
By Ronald G. Garby ISBN 0-920855-16-4

Reference Authority

1. WorkSafeBC Occupational Health and Safety Regulation (OHSR)
2. CAN/CSA-Z150-20 Safety Code for Mobile Cranes
3. ANSI Standard ANSI/ASME B30.5-2021, Mobile and Locomotive Crane



BC Association for Crane Safety
PO Box 42066 RPO Guildford
Surrey, BC V3R 1S5

Phone: 604-336-4699 | Fax: 604-336-4510
Email: info@bccranesafety.ca
www.bccranesafety.ca

© 2021 BC Crane Safety. All rights reserved.